

SCALE 2,000

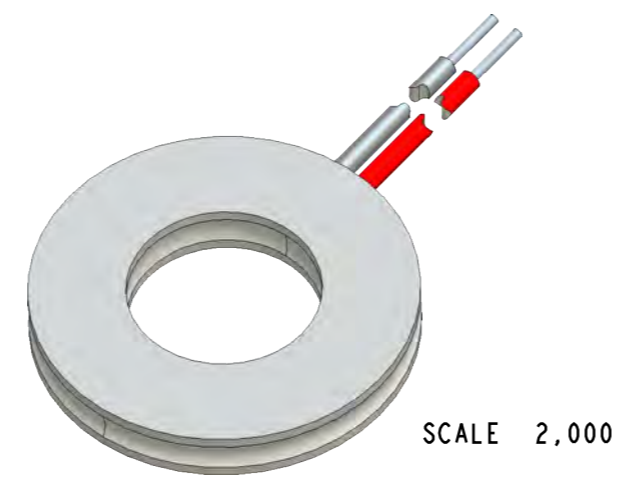

SCALE 2,000

REVISIONS					
REV.	POS.	DESCRIPTION	DATE	DRW	APP
A		INITIAL CREATION	2013/01/01	Gary	Mason

Curve Chart(Be Confined To TE01-036061326):

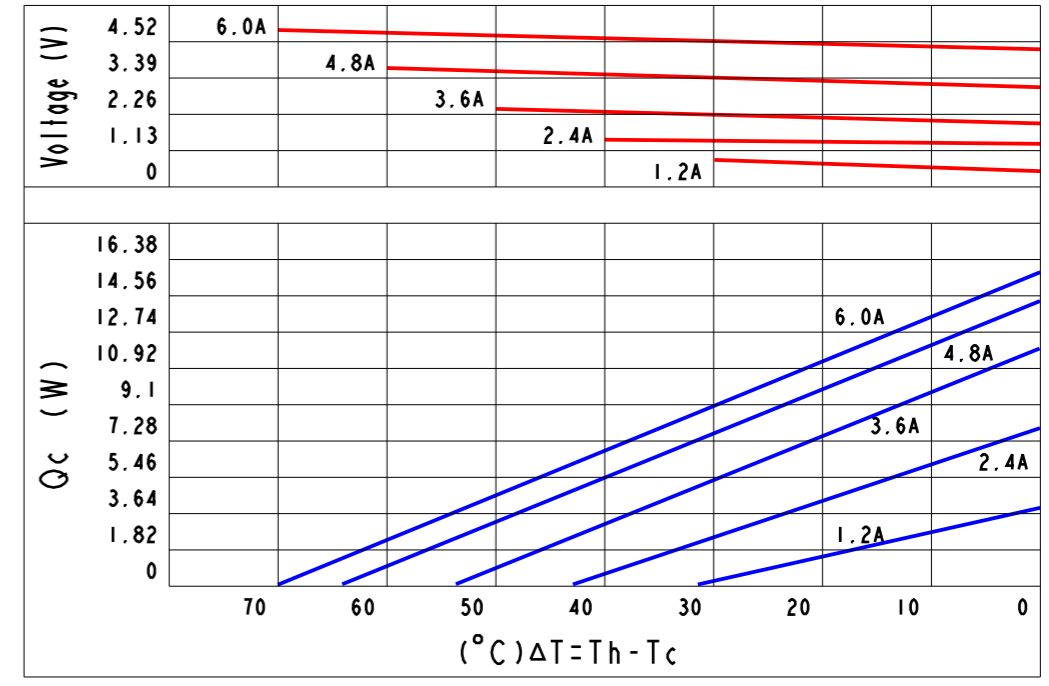

Part Number And Feature:

T	E	O	I	-	0	3	6	x	x	1	3	2	6	Sealing	YES
↓	↓				↓	↓	↓	↓	↓					Operation Temperature	125°C(Max.)
Thermo	Electric	Chip(O Type)	Stage	Stack	N & P	Stack	Quantity	Current	A(Max.)	Dimension	(A)	Dimension	(B)	Melting Point	138°C
														Storage Temperature	-60°C~100°C
														RoHS	YES

Technical Data:

ITEM	Part NO.	Stack(P&N)	A(Max.)	V(Max.)	Qc(W) /Th=27°C/ ΔT(°C)	DIM(A)	DIM(B)	DIM(H)
1	TE01-036041326	36	4 A	4.5 V	11W	70°C	Ø13	Ø26
2	TE01-036061326	36	6 A	4.5 V	16.3W	70°C	Ø13	Ø26

Notes:

1. Printing always on cold side.
2. Tolerance of thermo and electric parameters ±10%.
3. Please mount heat sink before you use it, also, please do not exceed the extra voltage at any time.
4. Please contact with us if you need Melting Point 183°C (Operation Temperature 150°C Max.) and 235°C (Operation Temperature 200°C Max.) type.

*DO NOT SCALE DRAWING

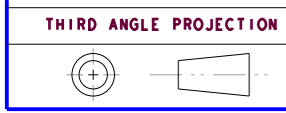

THIS DRAWING AND THE DATA DISCLOSED HEREIN OR HEREWITH IS NOT TO BE REPR ODUCE
USED OR DISCLOSED OR IN PART TO ANYONE WITHOUT THE PERMISSION OF KJLP (SHENZHEN) ELECTRONICS
CO., LTD.

1. UNLESS OTHERWISE SPECIFIED,
DIMENSIONS ARE MM
2 TOLERANCE ARE AS FOLLOWS:
0 < X < 2 ± 0.06
2 < X < 10 ± 0.08
10 < X < 50 ± 0.12
50 < X < 100 ± 0.16
100 < X < 200 ± 0.20
200 < X < 300 ± 0.30
ANGLES ± 0.5°

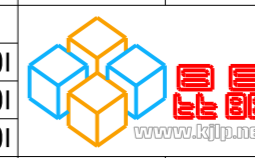
PART NO.	TE01-036xx1326	DESCRIPTION	DC 4.5V(Max.), 4~6A(Max.), 36 P&N, Ø13*Ø26mm
SIGNATURE	DATE	 昆晶冷片(深圳)电子有限公司 KJLP(SHENZHEN)ELECTRONICS CO., LTD email: kjlp@kjlp.net http://www.kjlp.net Tel: +86-755-82528352 Fax: +86-755-22639899	
DRAWN BY	Gary	2013/01/01	
CHECKED BY	Justin	2013/01/01	
ENGR	Vivi	2013/01/01	
APPROVED BY	Mason	2013/01/01	
ISSUED BY	Jack	2013/01/01	
MATERIAL:		CAD MODLE:	TE01-036xx1326.prt
		CAD DWG:	TE01-036xx1326.drw
		SCALE:	1:1
		REV:	A
		SIZE:	A3
		SHEET:	1 OF 1