

REVISIONS					
REV.	POS.	DESCRIPTION	DATE	DRW	APP
A		INITIAL CREATION	2013/01/01	Gory	Mason

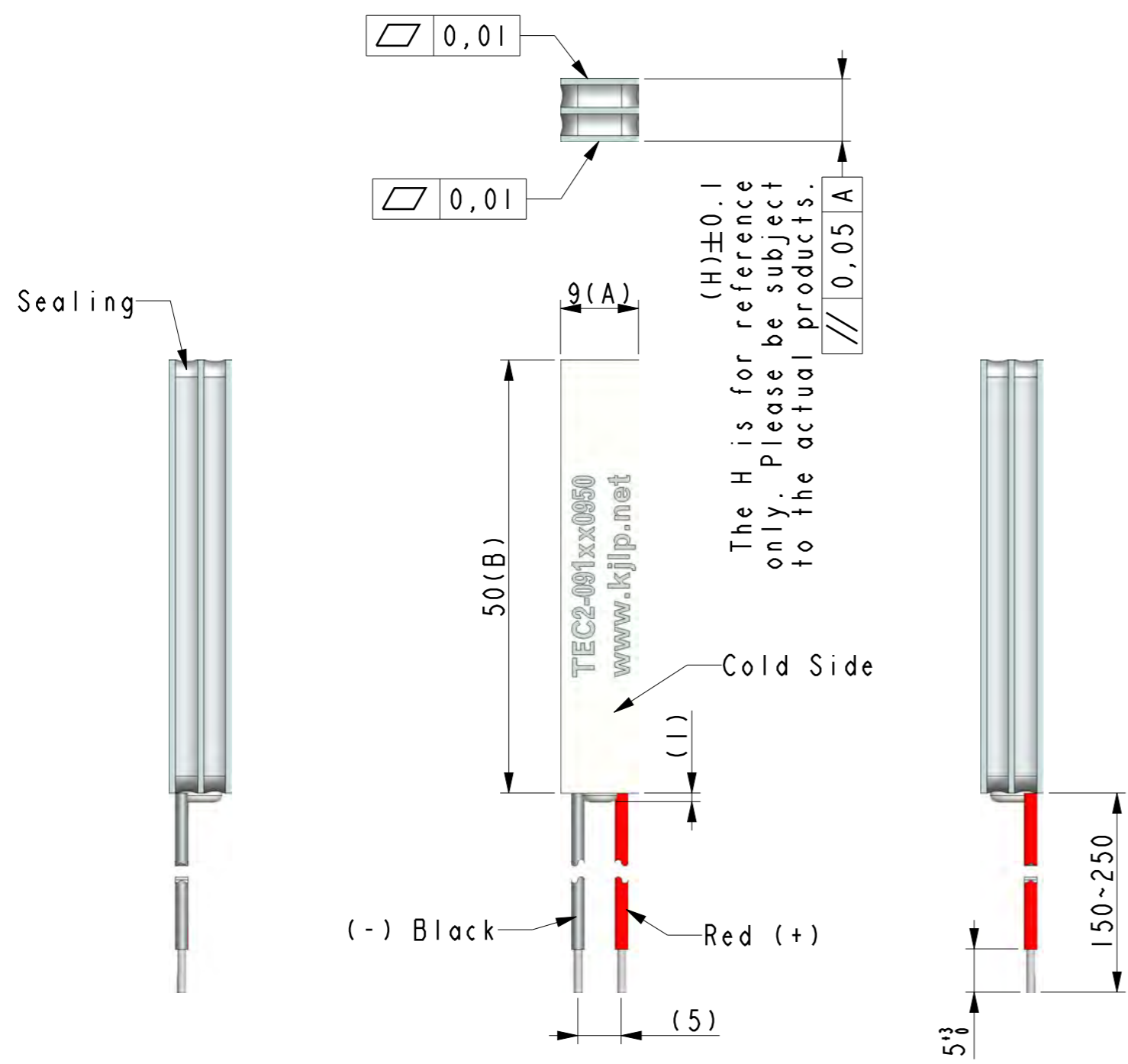

Curve Chart(Be Confined To TEC2-091030950):

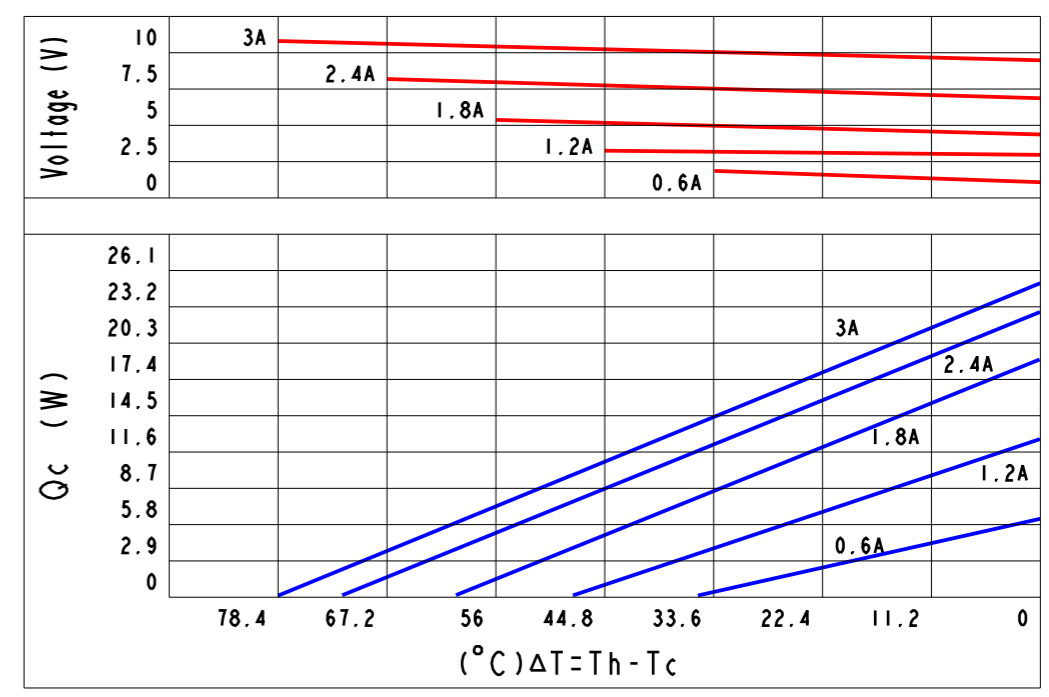

Part Number And Feature:

T	E	C	2	-	0	9	1	x	x	0	9	5	0	Sealing	YES
↓	↓				↓	↓	↓	↓	↓	↓	↓	↓	↓	Operation Temperature	125°C(Max.)
Thermo	Electric	Chip	Stage	Stack	N & P	Stack	Quantity	Current	A(Max.)	Dimension	(A)	Dimension	(B)	Melting Point	138°C
														Storage Temperature	-60°C~100°C
														RoHS	YES

Technical Data:

ITEM	Part NO.	Stack(P&N)	A(Max.)	V(Max.)	Qc(W) /Th=27°C/ ΔT(°C)	DIM(A)	DIM(B)	DIM(H)
1	TEC2-091020950	91	2 A	10 V	18W / 78°C	9	50	RF7.0
2	TEC2-091030950	91	3 A	10 V	26W / 78°C	9	50	RF10

Notes:

1. Printing always on cold side.
2. Tolerance of thermo and electric parameters ±10%.
3. Please mount heat sink before you use it. also, please do not exceed the extra voltage at any time.
4. Please contact with us if you need Melting Point 183°C (Operation Temperature 150°C Max.)

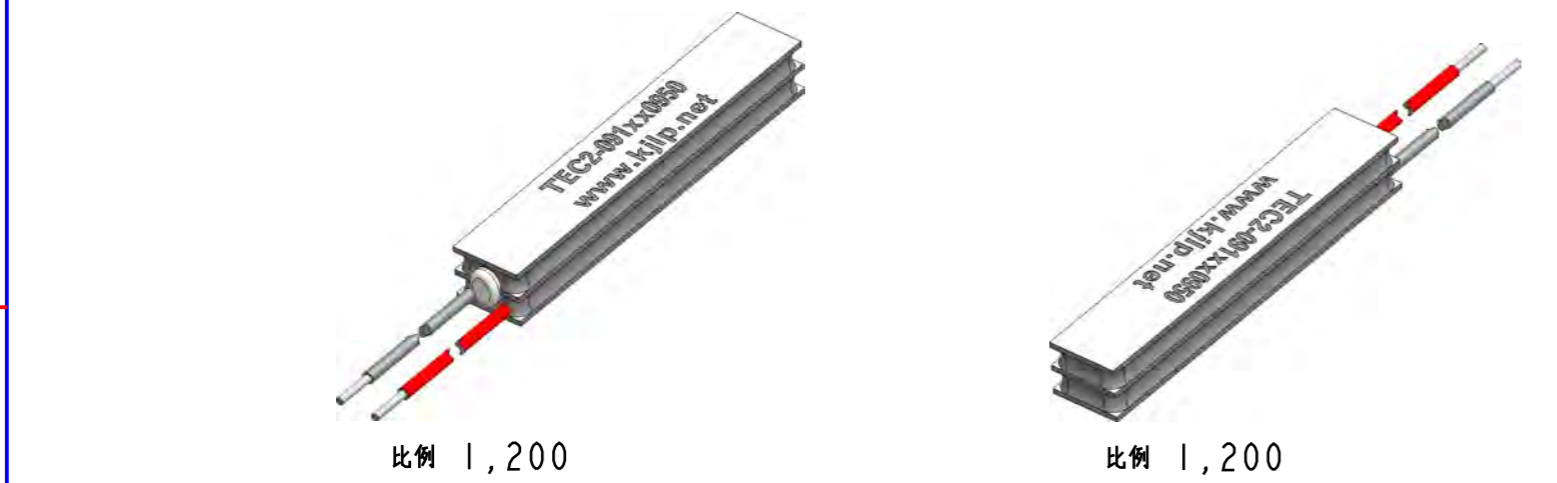

*DO NOT SCALE DRAWING

THIRD ANGLE PROJECTION

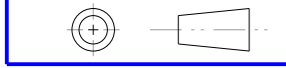

THIS DRAWING AND THE DATA DISCLOSED HEREIN OR HEREWITH IS NOT TO BE REPR ODUCE
USED OR DISCLOSED OR IN PART TO ANYONE WITHOUT THE PERMISSION OF KJLP (SHENZHEN) ELECTRONICS
CO., LTD.

1. UNLESS OTHERWISE SPECIFIED,
DIMENSIONS ARE MM
2 TOLERANCE ARE AS FOLLOWS:
0 < X < 2 ± 0.06
2 < X < 10 ± 0.08
10 < X < 50 ± 0.12
50 < X < 100 ± 0.16
100 < X < 200 ± 0.20
200 < X < 300 ± 0.30
ANGLES ± 0.5°

PART NO.	TEC2-091xx0950	DESCRIPTION	DC 10V(Max.),2~3A(Max.),91 P&N,9*50mm		
SIGNATURE		DATE	昆晶冷片(深圳)电子有限公司		
DRAWN BY	Gory	2013/01/01	KJLP (SHENZHEN)ELECTRONICS CO., LTD		
CHECKED BY	Justin	2013/01/01	email: kjlp@kjlp.net http:// www.kjlp.net		
ENGR	Vivi	2013/01/01	Tel: +86-755-82528352 Fax: +86-755-22639899		
APPROVED BY	Mason	2013/01/01	CAD MODLE:	TEC2-091xx0950.prt	SCALE: 1:1 REV: A
MATERIAL:	ISSUED BY	Jack	2013/01/01	CAD DWG:	TEC2-091xx0950.drw
					SIZE: A3 SHEET: 1 OF 1